

User Manual

Standing Projection Screen / Electric Motorized Projection Screen

No.50490, No.50491, No.50492, No.50493, No.50494
No.50495, No.50496, No.50497, No.50498, No.50447

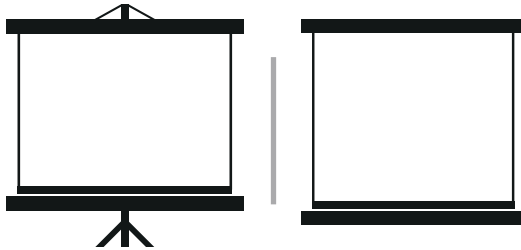

Reminder: Please read this manual carefully before use and follow the instructions to operate properly.

(Reserved for future use)

Care and maintenance

1. Keep the screen away from doors, windows, and fans to avoid damage caused by blowing air.
2. Keep the screen away from direct sunlight or rain to slow aging.
3. While expanding the screen, do not pull forcefully, try to exert even force, retract the screen in a vertical position.
4. Do not touch the surface of the screen with sharp objects to avoid damage to the screen.
5. When not in use, retract the screen into its shell to avoid dust accumulation.
6. Stains on the surface of the screen should be wiped clean gently with a cotton cloth dipped in neutral detergent or water. Only use or retract the screen after drying.

I. Standing Projection Screen

Packing List

Please check if the product is intact after unpacking and verify that all the accessories have been received. If any items are missing, please contact your dealer.

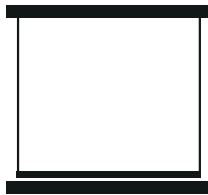

Screen

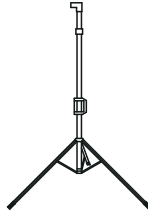

Tripod

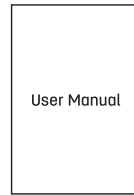

User Manual

(including warranty card and quality certificate)

Instructions for Use

1. Place the stand on a level surface, open the "tripod lock", fully open up the "tripod", and then place it stably on the floor.
2. Connecting screen shell and stand: press down on the stand's middle button, and then insert the screen shell into the latch. The button will return to its original position once fully inserted.
3. Release the screen, then pull it over the hanging clip ① to adjust the height of the height lock ② or handle ③.
4. To retract the screen after use, use your left hand to hold the upper support rod ④ while using your right hand to press the height lock ② to ensure the upper support rod slides down slowly.

(Note: The screen exerts a heavy pulling force when retracting. Retract the screen with caution. To prevent your hand from being caught, hold the upper support rod with your left hand while pressing the height lock with your right hand to ensure that the upper support rod slides down slowly!)

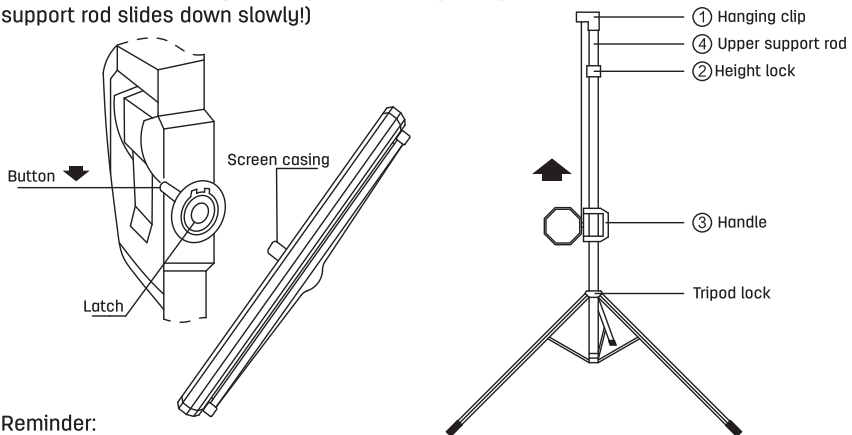

Reminder:

- > Place the screen stand horizontally to prevent tilting.
- > The height of the stand and the screen can be adjusted based on your actual image projection requirements.

II. Electric Motorized Screen

Packing List

Please check if the product is intact after unpacking and verify that all the accessories have been received. If any items are missing, please contact your dealer.

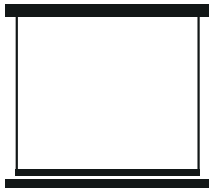

Electric motorized screen

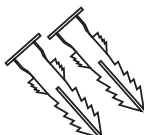

Expansion anchor (x2)



Self-tapping screw (x2)

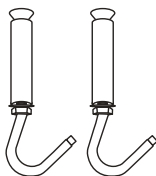

Screw hook (x2)

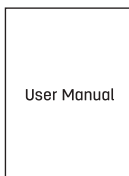

User Manual

(including warranty card and quality certificate)

Note: This diagram is for reference only, please take the actual product as standard.

Operating Instructions

1. Connect the 220V AC power supply
2. Lower the screen: Press the "=" button on the switch
3. Retract the screen: Press the "-" button on the switch
4. Stop retracting/lowering: Press the "0" button on the switch
5. When fully lowered or retracted, the screen will automatically stop.

Reminder:

The motorized screen should not be operated continuously for more than 5 minutes at a time, or the motor will overheat and possibly suffer damage. If operated continuously for more than 5 minutes, allow 5 minutes of rest before using the screen again.

The projected image may suffer from distortion when using a short-focus or ultra-short-focus projection equipment.

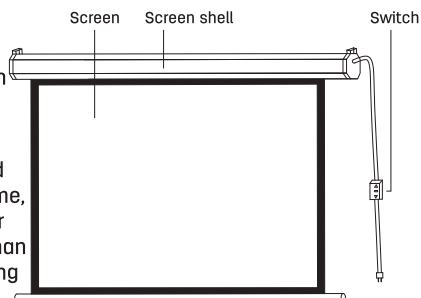

Installation methods

1. Wall installation

Measure the distance between the mounting holes. You may find two keyhole-shaped hanging rings at both ends of the casing. To hang the projection screen on a wall, drill holes with an electric drill ($\Phi 6\text{mm}$ drill bit) at the appropriate positions on the wall, install the expansion anchors and screw in the self-tapping screws (leave a space of 5mm between the screw and the anchor), and then hang the screen.

2. Ceiling installation

When ceiling installation is required, measure the distance between the hanging rings, drill holes in the appropriate positions on the ceiling with an electric drill ($\Phi 8\text{mm}$ drill bit), install the expansion anchors and screw in the expansion hook screws and tighten the nuts, then hang the screen by attaching the rings at both ends of the casing.

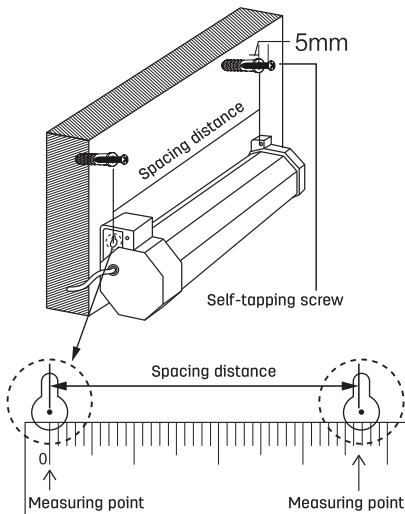

Wall installation

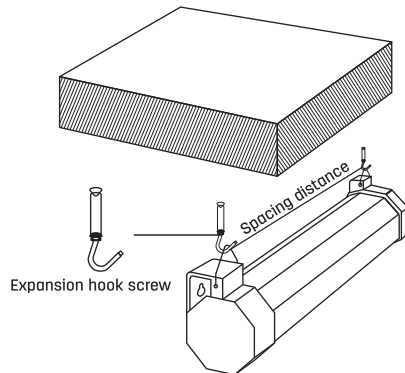

Ceiling installation

Note: The distance between drilled holes required to install the electric motorized remote control projection screen should be determined by the actual measurement value.

Please use metal expansion hook screws ($\Phi 8\text{ mm}$ drill bit) to mount on hard brick or concrete walls. To mount your screen on ceiling, please hire a professional installation team.

Warranty Card

Dear customers:

Thank you for your purchase of our products. The interests of customers who purchase our products will be protected. For any malfunction due to product quality problems, please contact authorized local dealers or service centers with this receipt and the warranty card.

Warranty terms:

1. For product failures occur under normal operating circumstances, free of charge repair service shall be provided by our company within one year commencing from date of purchase. (If factory repair service is needed, customer shall bear the freight for delivery of the returned product.)
2. Customers are required to present this warranty card and the original purchase invoice to our company upon request for warranty service. This warranty card shall be valid only after the following form is filled out in details and affixed with official seal of the dealer.
3. No free of charge repair service shall be provided in the event of any of the following circumstances:
 - (1) Expiration of the warranty period;
 - (2) Damages caused by improper use, maintenance or storage not in accordance with the requirements of the user manual;
 - (3) Failure or damage resulting from unauthorized disassembly, repair or modification;
 - (4) Failure or damage caused by force majeure.

This warranty card is being delivered with the product, one card for one product. Please keep this warranty card in proper condition for free warranty service. There is no replacement if lost.

Date of Purchase: MM/DD/YYYY