

USER MANUAL

THERMAL RECEIPT PRINTER

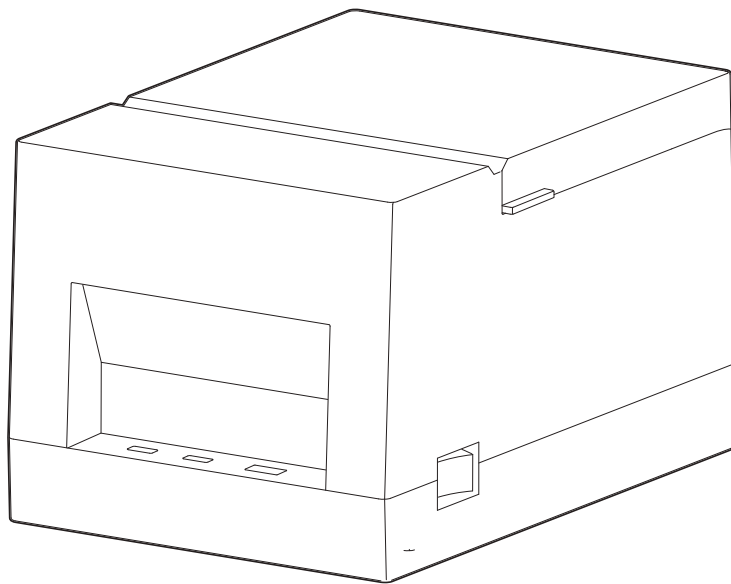

MODEL: 581P

CONTENTS

STATEMENT.....	
SAFETY PRECAUTIONS.....	
CHAPTER 1. PRODUCT INTRODUCTION.....	
1.1 Brief introduction.....	
1.2 Features.....	
1.3 Unpacking checklist.....	
1.4 Physical appearance and components.....	
1.5 Product dimensions.....	
CHAPTER 2. PRODUCT SPECIFICATIONS.....	
2.1 Technical specifications.....	
2.2 Technical specifications of printer consumables.....	
2.3 Printing / cutting position.....	1
CHAPTER 3 INSTALLATION AND OPERATION.....	
3.1 Loading the paper roll.....	
3.2 Connecting the power cord.....	
3.3 Connect to the cash drawer	
3.4 Description of indicator	
3.5 Printing test.....	
3.6 Use of Bluetooth.....	
CHAPTER 4 INTERFACE SIGNAL.....	
4.1 USB.....	
4.2 Cash drawer.....	
CHAPTER 5 TROUBLESHOOTING.....	
5.1 Printer stops functioning.....	
5.2 Error indicator	
5.3 Problems during printing.....	
CHAPTER 6 CLEANING THE PRINTER.....	
6.1 Cleaning the print head.....	
6.2 Cleaning the sensor, roller and paper path.....	

STATEMENT

The content of this manual should not be changed without prior written permission. Deli Group Co., Ltd. reserves the right to make any change on the technology, parts, software and hardware of this product. If you need additional information about this product, please feel free to contact Deli Group Co., Ltd. No part of the contents from this manual may be reproduced or transmitted in any form or by any means without the written permission of the company.

copyright

This manual was printed in 2019 and its copyright belongs to Deli Group Co., Ltd.

Printed in China.

Version 1.0

Warm Reminder:

Dear customer, thank you for purchasing our products. To protect your after-purchase rights, please fill out the attached product warranty card. (Warranty service will not provide without a valid warranty card)

SAFETY PRECAUTIONS

Please read the precautions carefully before operating the printer to avoid personal injury or machine damage.

1. Warning symbols

 WARNING Must be followed to avoid injury to the user and/or damage to the equipment.

 Note Signals important information and tips for printer operation.

2. Safety precautions

 WARNING: Violating following instructions may cause serious injury or death.

1) Do not insert several plugs into a multi-outlet power strip at the same time.

- This can cause overheating and a fire.
- If the plug is wet or dirty, dry or wipe it clean before use.

-
- Do not use the electrical outlet if it's not compatible with the power cord plug.
 - You should only use standard multi-outlet power strips.
- 2) You should only use the adapter provided in this package.
 - It is not safe to use other adapters.
 - 3) Do not unplug it by pulling on the power cord
 - This may damage the power cord and cause a fire or printer malfunction.
 - 4) Do not plug or unplug the power cord with wet hands.
 - This may cause electric shock.
 - 5) Do not bend the power cord excessively or place heavy objects on it
 - Damaged power cords may cause a fire.

⚠ Note: Violating following instructions can cause slight wound or damage the appliance .

- 1) If you find smoke, smell or noise coming out of the printer for unknown reason, please unplug the power cord and take proper emergency measures.
 - Turn off the printer and unplug power cord.
 - After the smoke clears, call the dealer for repairs.
 - 2) Place the printer on a stable and flat surface.
 - If the printer drops to the ground, it may break and cause personal injury.
 - 3) You should only use approved accessories, and do not attempt to disassemble, repair or modify the printer by yourself.
 - Please call the dealer if you need any of the above-mentioned services.
 - 4) Do not let water or other objects get inside the printer.
 - In case it happens, turn off the printer and unplug the power cord. Then call the dealer for service.
 - 5) Do not use the printer when there is a malfunction, as this may cause fire or electric shock.
 - Please turn off the printer and unplug the power cord. Then call the dealer for service.
-

6) Other matters to note.

Leave enough space around the printer for operation and maintenance purpose

Keep the printer away from water, direct sunlight, strong light and heat sources.

Do not use or store the printer in places with high temperature, high humidity or heavy pollution.

Avoid placing the printer in places subject to vibrations and shocks.

Connect the printer's power adapter to a properly grounded electrical outlet, and avoid using the same outlet with large appliances or devices that can cause voltage fluctuations.

Please disconnect the power supply if you are not going to use the printer for a long period of time.

To ensure print quality and extend the life of the printer, it is suggested to use recommended or equivalent quality printer paper.

Shut off the power before plugging or disconnecting of interfaces, otherwise it may damage the printer control circuits.

Please keep this manual in a proper place for future references.

3. Other matters to note

Although we have been very careful on the compiling of this manual, however, errors and/or omissions are still inevitable. The company will not assume any responsibility for any losses on anyone due to the use of information in this manual. For users and third parties, the company and its subsidiaries will not be liable for any product damage, failure or misuse caused by not following or ignoring the operation, maintenance information and/or instructions provided by the company; and for losses, costs or expenses caused by unauthorized changes, repairs or modifications to the product. The company shall not bear any responsibility with regard to damages and/or problems caused by the use of counterfeit accessories, parts or unauthorized products.

Note: Due to continuous product improvement, specifications, accessories and/or procedures described herein are subject to change without notice.

4.WEEE (Waste Electrical and Electronic Equipment)



The symbol placed on the product indicates that the item should not be mixed with general household waste. If such waste is not properly managed, it may harm both environment and human health. To prevent possible harm to the environment or human health from uncontrolled waste disposal, please separate these items from other types of waste and recycle them responsibly to promote the sustainable reuse of material resources. Household users should contact either the retailer where they purchased this product, or their local government office, for details of where and how they can take these items for environmentally safe recycling. Business users should contact their supplier and check the terms and conditions of the purchase contract. This product and its accessories should not be mixed with other commercial wastes for disposal.

1 PRODUCT INTRODUCTION

1.1 Brief introduction

DL-581P(NEW)/DL-581PW(NEW)/DL-581YW is a thermal receipt printer with an automatic cutter. The printer features high print quality, high speed and great stability and it is widely used to work with POS systems in catering industry and other occasions that require on-site real-time printing of receipts. DL-581P(NEW) / DL-581PW(NEW)/DL-581YW printers can be connected to other devices via USB and cash drawer connector and support drivers like WINDOWS XP/7/8/10/vista and more.

1.2 Features

- 1) Low noise, high speed printing;
- 2) Convenient paper loading ;
- 3) Easy to use and maintain;
- 4) Cash drawer connector;
- 5) Automatic paper cutting

1.3 Unpacking checklist

- 1) Unpack the printer and save the packing materials in case you need to repack the printer for shipping or storage.
- 2) Please contact the dealer for any defect and/or missing of accessory.

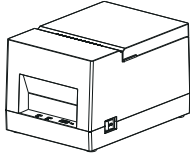

Printer

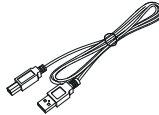

USB cable



power cord

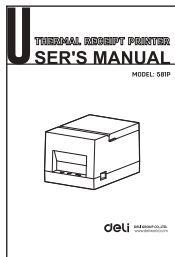

user manual

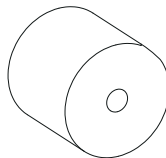

paper roll

E581P printer support Bluetooth function.

1.4 Physical appearance and components

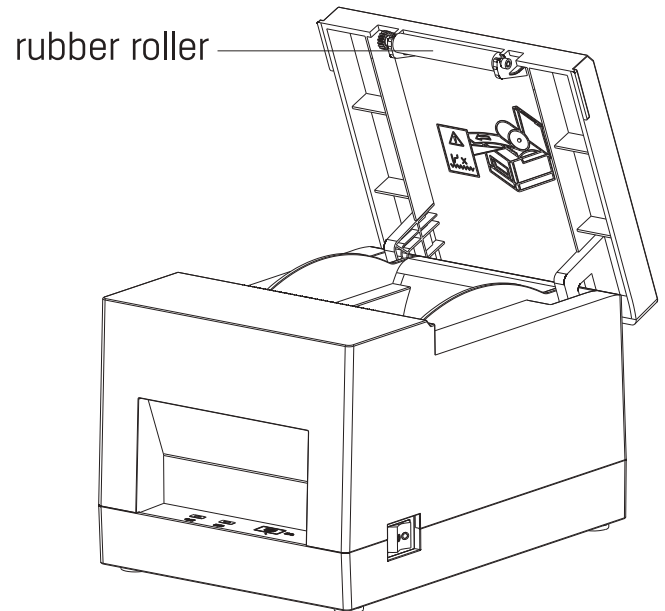
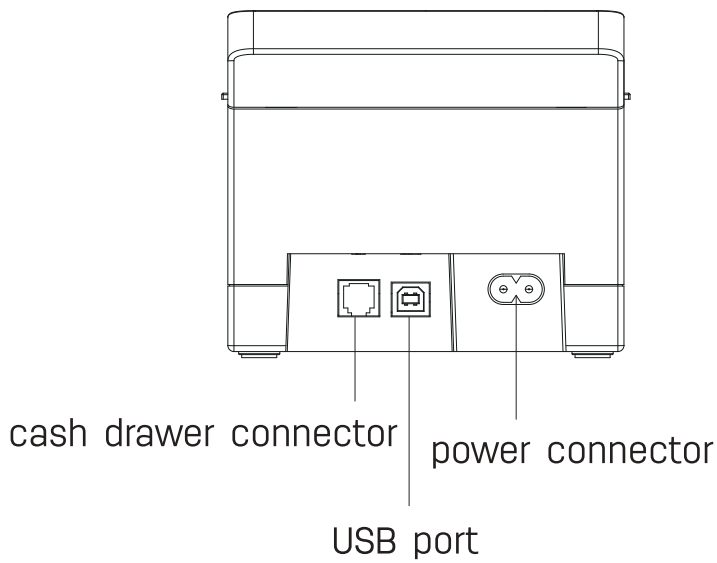
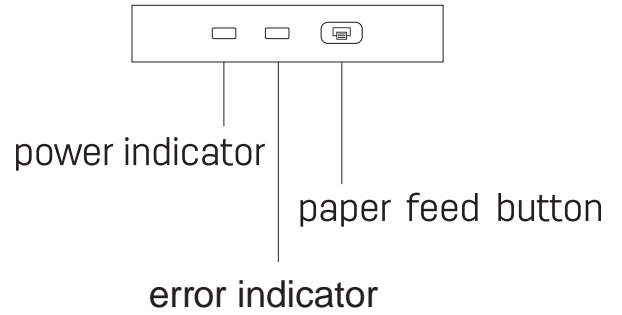
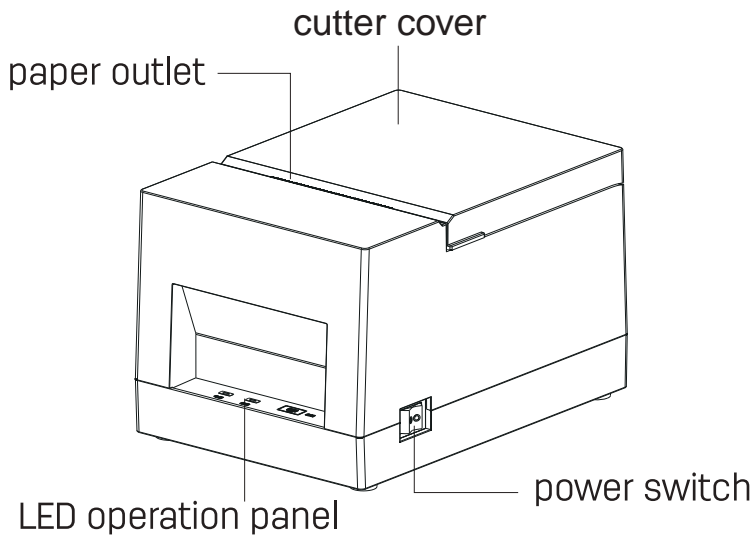

1.5 Product dimensions

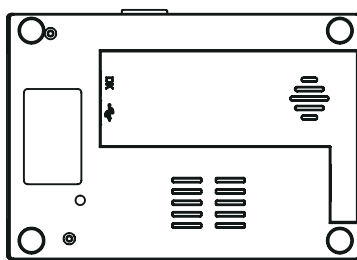
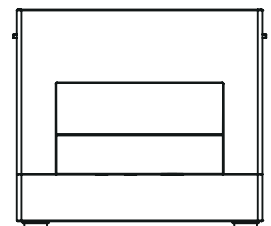
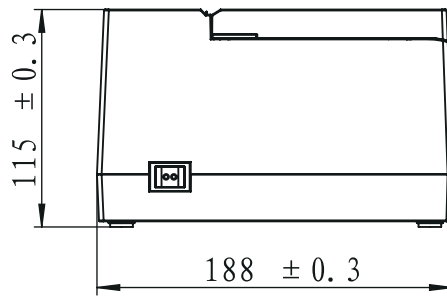
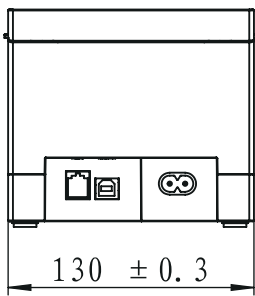
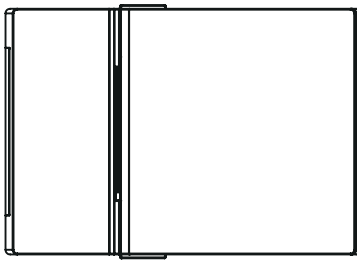
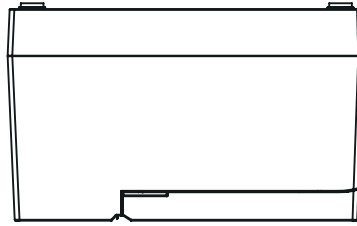

Unit: mm

2.Product Specifications

2.1Technical Specifications

Item		Parameter
Printing	Print method	Direct thermal
	Print resolution	203 dpi 8 dots/mm
	Printing speed	70mm/s
	Print width	48mm
	Print density	14 level (adjustable)
Processor		32-bit RSIC
Flash memory (optional)		2MB
Detection	Sensor	Out of paper detection
Power	Type	built-in power adapter
	Input	AC100V-240V 1A 60/ 50HZ
	Output	8.5 V --- 15A
Paper supplies	Type	Standard thermal paper
	Width	58±0.5mm
	Thickness	0.050~0.090mm
	Paper roll diameter	MAX 70mm
	Paper loading	Top open cover for easy paper loading
Instruction set		ESC/ POS
Software function	Driver	Windows XP/ Win7/ Win8/ Win10/ Vista/ Linux/ CPOS
Characters	Chinese	GBK 16*16 2 4*24dots
	English	ASCII 9x17 1 2x24dots
	Character sets	PC437/ Katakana/ PC850/ PC860/ PC863/ PC865/ West Europe/ Greek/ Hebrew/ EastEurope/ Iran/ WPC252/ PC866/ PC852/ PC858/ Iran/ Latvian/ Arabic/ PT61251/ PC737/ WPC 1257/ Thai/Vietnam/ PC864/ PC001 (Latvian)/(PC001)/(PT61251)/(WPC257)/(PC864)
Graphics		Support bitmap printing with different density and user defined bitmap printing. (Max size of each bitmap is 40K, the total size of bitmap is 64 K)
Barcodes	1D	UPC-A, UPC-E, EAN8, EAN13, CODE39, ITF, CODEBAR, CODE128, CODE93
LED indicator	Power indicator	Green
	Error indicator	Red
Environment parameters	Operating	5 to 50 ℃, 25% to 85%RH(no condensation)
	Storage	-40 to 60 ℃, 10% to 90%RH(no condensation)
Physical parameters	Dimensions (LxHxW)	188 X130 X 115mm
	Weight	980G
Reliability parameter	TPH life	50km
Certificate		CE

2.2 Technical specifications of printer consumables

2.2.1 Continuous paper parameters

- 1) Paper type: Thermal receipt paper
- 2) Paper width: Supported 58^{+0}_{-1} mm printer paper
- 3) Paper thickness: 0.050 ~ 0.090mm
- 4) Recommended paper

Type N0. 11721 , N0. 3142

manufacturer DELI GROUP CO., LTD.

2.2.2 Notes

⚠ Note:

- 1) Please use recommended paper or equivalent quality paper. Using the wrong types of paper may affect the printing effect and will shorten the lifespan of the printhead
- 2) Do not paste the paper to the core of the paper roll;
- 3) Chemical agents or oil contaminated paper may fade or lose its heat sensitivity which will affect the printing result;
- 4) Do not rub the surface of the printer paper with nails or hard objects, otherwise it may cause discoloration;
- 5) The printer paper will develop color at a temperature of 70 ℃. Pay attention to temperature, humidity and light for paper-storage.

2.3 Printing / cutting position

2.3.1 Printing position

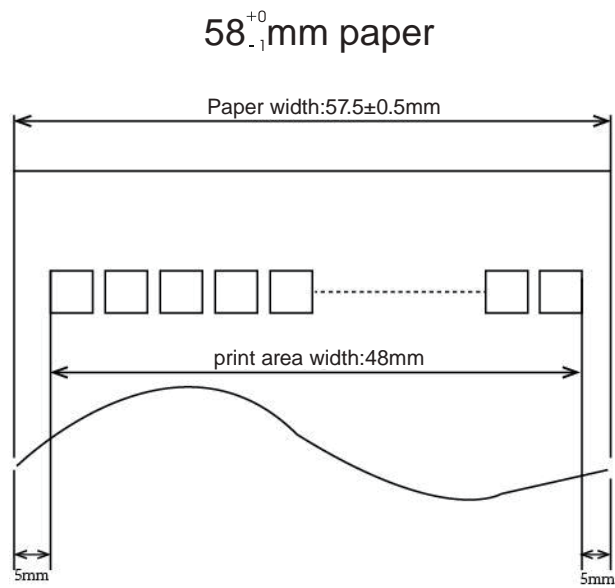

2.3.2 Cutting position

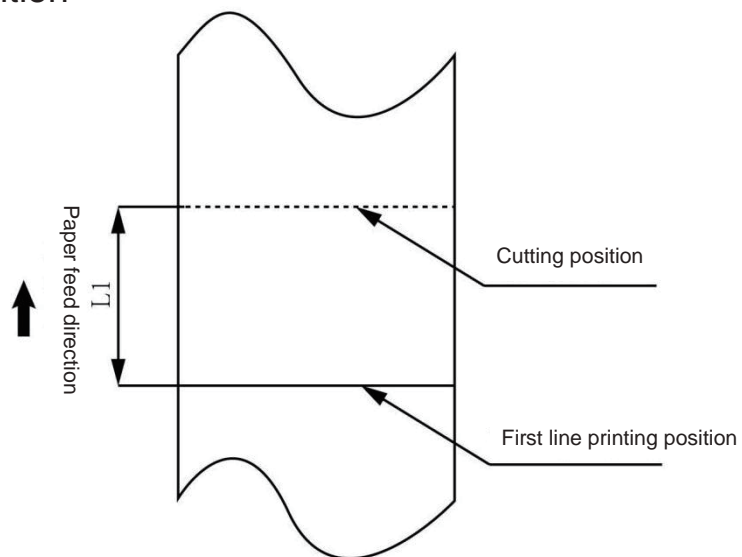

Type	Cutting position (L1)
DL-581P(NEW)/DL-581PW(NEW)/DL-581YW	13 mm

3 INSTALLATION AND OPERATION

3.1 Loading the paper roll

- 1 Face toward the front panel and open the paper roll cover by pushing it up in the direction of arrow (as shown below).
2. Please remove the paper roll if necessary.

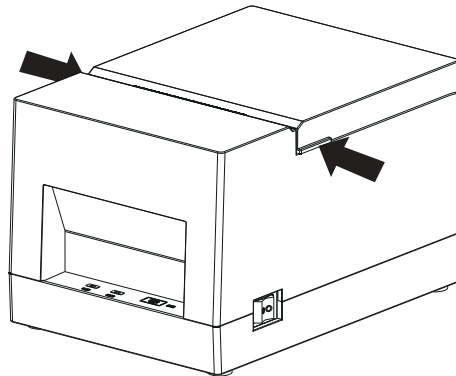

3. Place a paper roll into the paper compartment, making sure it's loaded in the right direction.

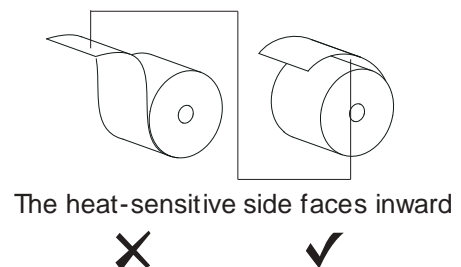
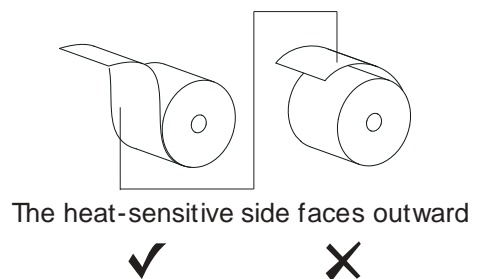
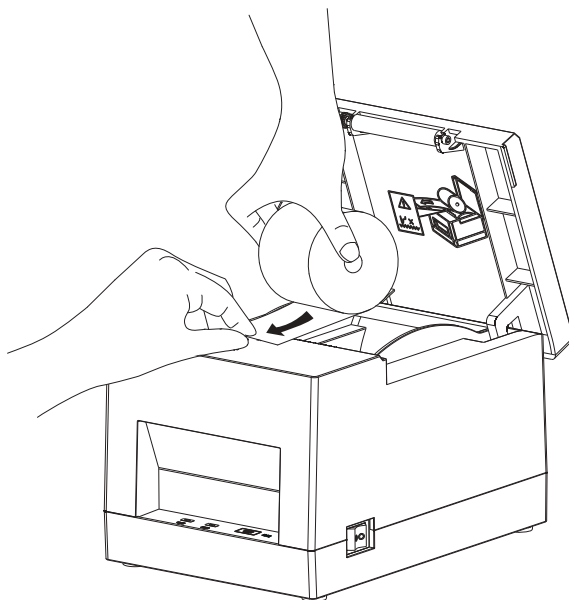

4. Please pull out a small amount of paper in the front , and then close the printer top cover.

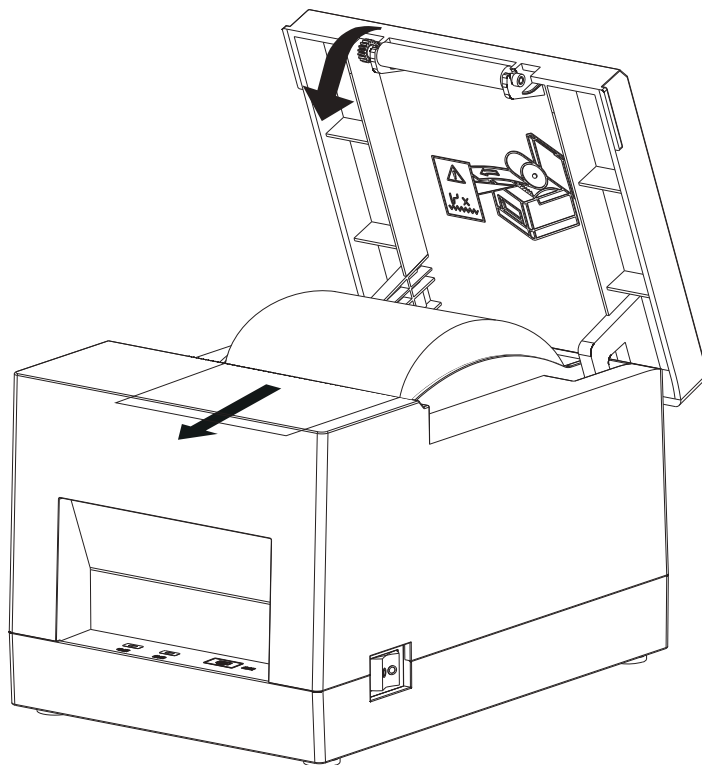

5. Tear off excess paper

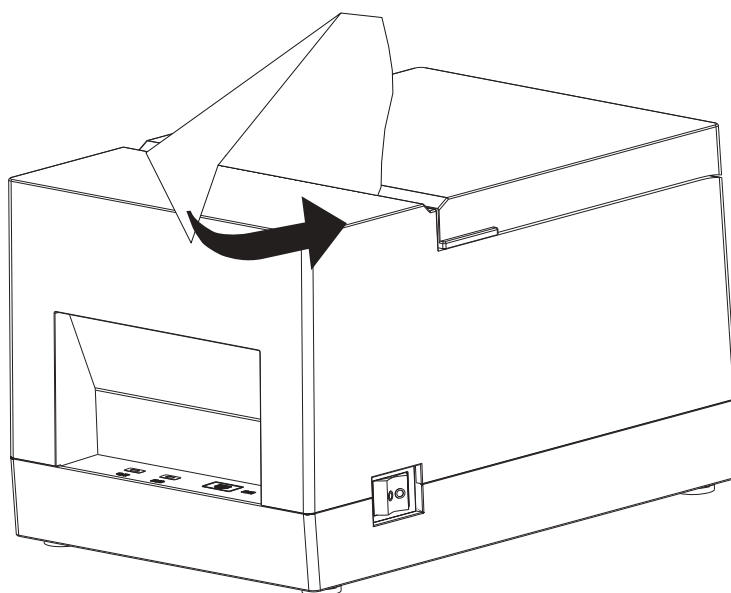

3.2 Connecting the power cord

1. Make sure the printer's power switch is off (O).
2. Connect the power adapter to the printer.
3. Plug the power cord into the other end of the power supply.

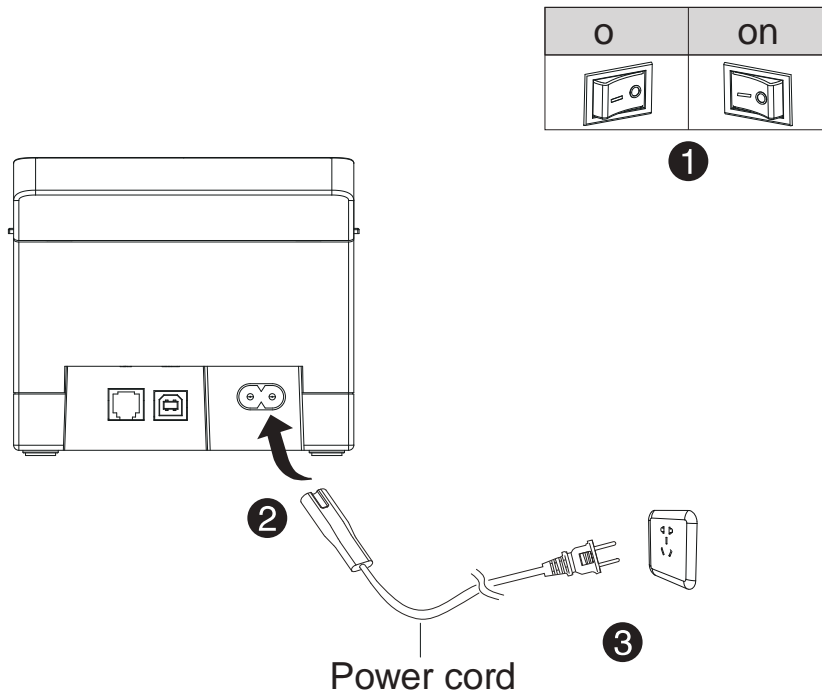

⚠ Note

- 1) Please use our company's original power adapter to avoid damage to the product and the possible cause of injury.
- 2) If you do not use the printer for a long period of time, unplug the printer power cable.
- 3) Avoid dragging the power adapter cable, as this may cause fire or electric shock.;
- 4) Avoid placing the power adapter around overheated equipment, as this may cause fire or electric shock.
- 5) When plugging and unplugging the power adapter plug, hold the connector shell of the plug in hand to avoid pulling the cable hard.

3.3 Connect to the cash register

- 1 Make sure the power switch of the printer is o ;
- 2 Insert the cash register connecting cable into the cash register port on the back of the printer.

Warning: The cash register interface can only be connected to a cash register device with a voltage of 12V (it should not be connected to a telephone line, etc.).

3.4 Description of indicator

Function description of Indicator

Name	Status	Description
Power indicator (Green)	Constantly on	The printer is functioning properly
	O	The printer stops functioning
Error indicator (Red)	Blinking	The printer is in error state
	O	The printer is functioning properly

Description	Power indicator	Erroe indicator
The printer cover is open	On	On
Out of paper	On	On
Full of paper lie down the cover not close the cover	On	O

⚠ Note: The printer uses a thermistor to detect printer head temperature. If the printer head temperature exceeds 70 °C, the printer will terminate its work until the temperature drops below 60 °C.

3.5 Printing test

3.5.1 Printing a self-test page

When the printer is initially installed, or if there is any problem with the printer, you can execute the self-check program to con rm the following status. Hardware version, printer parameter setting status, if you con rm no problems with the printer after the self-check, such as printing quality and related setting information of external devices, please check other devices or software. This function runs independently with other devices or software.

This is the self-test is process:

- 1) Ensure the power is connected, and the paper roll is properly installed.
- 2) Make sure that the printer is on and the top cover is properly shut.
- 3) Wait until the red light is on, release the paper feed button to print the printer self-check page.

3.5.2 Printing with Windows driver

- 1) Please refer to the "Windows Driver Manual" to complete the installation.
- 2) Set the "Port" of the Windows driver to the corresponding interface.
- 3) Use the "Print Test Page" function of the Windows driver to print a test page.

3.6 Use of Bluetooth

It needs to be paired with the main device before using Bluetooth to print. The pairing process is initiated by the main device.

The usual pairing method as follows:

- 1 Turn on the printer;
2. Search for external Bluetooth devices through the main device ;
3. If there are multiple external Bluetooth devices, select the printer;
4. Complete matching

When pairing, the printer must be on.

Tips When pairing, please pair one-to-one, otherwise it may not be able to determine which printer is paired successfully. After pairing successfully, other host computers cannot be paired with the printer. If you need to pair with other upper computers, you need to disconnect it first.

Print Using Bluetooth Interface:

For PCs with virtual Bluetooth serial ports (such as mobile phones using SMARTPHONE, POCKET PC, PALM, notebook computers, etc.), after pairing successful, you can send print data to the printer through the virtual Bluetooth serial port for printing.

Notes: E581P does not support Bluetooth function.

4 Interface signal

581P(NEW)/581PW(NEW)/581YW printer supports cash drawer interface and multiple communication interfaces: USB interface, cash drawer interface.

4.1 USB

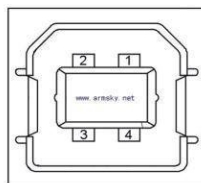

Pin number	Signal name
1	VBUS
2	D-
3	D+
4	GND

4.2 Cash drawer

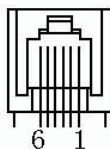

Pin number	Signal name
1	FG
2	Drawer 1
3	DRSW
4	VDR
5	Drawer 2
6	GND

Electrical characteristics:

Drive voltage: 12V DC

Drive current: 1.0A max

Cashdrawer status detection signal: "L" =0 j0.5V; "H" =3 j5V

5 TROUBLESHOOTING

If you cannot solve a problem using the troubleshooting tips in this section, you may need to call technical support. Please contact your dealer or manufacturer for assistance.

5.1 Printer stops functioning

Problem	Possible Cause	Solution
Indicator light is not on, The printer is not responding	Printer has no power	Connect the printer power
	Printer is not turned on	Turn on the printer
	The circuit board is broken	Contact the dealer or manufacturer

5.2 Warning indicator

Problem	Possible Cause	Solution
Error indicator is on and the printer beeps	The top cover is lifted up	Close the top cover
Paper status indicator and errorindicator are on and the printer beeps	Paper is low	Change the paper roll
Error indicator and paper status indicator are both flashing and the printer beeps	Printer head has overheated	Turn o the printer and allow printer head cool down
	Printing overpressure	Print with speci ed voltage
	Printing low pressure	Print with speci ed voltage

5.3 Problems during printing

Problem	Possible Cause	Solution
Print is light or spotty	Paper roll is loaded incorrectly	Check if the paper roll is loaded correctly
	Printing paper is not qualified	Replace with recommended thermal paper
	Print head or rubber roller is dirty	Clean the print head or rubber roller
	The print density is set too low	Increase the print density to meet the requirement
Paper cannot be feed out normally	Paper jam	Open the upper cover, check the paper path, and clear the jam
Portrait print content is missing	Dirty printer head or roller	Clean the printer head and roller
	Printer head is out of order	Contact the agent or manufacturer

6 CLEANING THE PRINTER

Printing quality might be degraded by dust, foreign substance, adhesive substance, or other pollution materials stuck in the printer head or inside the printer. When dirty, clean the print head as follows

Caution

- 1) Make sure to turn the printer power off prior to cleaning.
- 2) Turn the printer off and wait for 2 -3 minutes before cleaning the printhead because it gets very hot during the printing process.
- 3) When cleaning the print head, take care not to touch the heated portion of the print head to avoid any damage caused by static electricity or other factors.
- 4) Take care not to allow the print head to become scratched and/or damaged in any way.

6.1 Cleaning the print head

- 1) Open the top cover of the printer, and then use the cleaning pen or a cotton swab dipped in diluted alcohol (or isopropanol) to clean the print head in the direction from the center of the head to the edges.
- 2) After cleaning the head, do not use the printer until the alcohol used for cleaning evaporates completely (1~2 min) and the printer head has completely dried.

6.2 Cleaning the sensor, roller and paper path

- 1) Open the top cover of the printer and take out the paper roller.
- 2) Remove any dust or foreign materials using a dry cotton cloth or cotton swabs.
- 3) Use an alcohol-soaked cotton cloth or cotton swabs to wipe off any adhesive substance or pollution materials
- 4) After cleaning the parts, do not use the printer until the alcohol used for cleaning evaporates completely (1~2 min) and the printer has completely dried.

Please clean the parts in case the print quality deteriorates or paper detection performance decreases