USER MANUAL

THERMAL RECEIPT PRINTER



MODEL: 740C

CONTENTS

STATEMENT.....	
SAFETY PRECAUTIONS.....	
CHAPTER 1 PRODUCT INTRODUCTION.....	5
11 Unpacking checklist.....	
12 Physical appearance and components.....	
13 Product dimensions.....	
Chapter 2. Product specifications.....	8
Chapter 3 Installation and Operation.....	9
3.1 Installation media	
3.2 Connecting the power cord.....	
3.3 Interface connection.....	
3.4 Label detection.....	
3.5 Operation panel.....	
3.6 Basic function.....	
CHAPTER 4 INTERFACE SIGNAL.....	21
CHAPTER 5 CLEANING THE PRINTER.....	22
5.1 Cleaning the print head.....	
5.2 Cleaning the sensor, roller and paper path.....	



STATEMENT

The content of this manual should not be changed without prior written permission. Deli Group Co., Ltd. reserves the right to make any change on the technology, parts, software and hardware of this product. If you need additional information about this product, please feel free to contact Deli Group Co., Ltd. No part of the contents from this manual may be reproduced or transmitted in any form or by any means without the written permission of the company.

copyright

This manual was printed in 2019 and its copyright belongs to Deli Group Co., Ltd.

Printed in China.

Version 1.0

Warm Reminder:

Dear customer, thank you for purchasing our products. To protect your after-purchase rights, please fill out the attached product warranty card. (Warranty service will not provide without a valid warranty card)

SAFETY PRECAUTIONS

Please read the precautions carefully before operating the printer to avoid personal injury or machine damage.

1. Warning symbols

⚠️ WARNING Must be followed to avoid injury to the user and/or damage to the equipment.

⚠️ Note Signals important information and tips for printer operation.

2. Safety precautions

⚠️ WARNING: Violating following instructions may cause serious injury or death.

1) Do not insert several plugs into a multi-outlet power strip at the same time.

- This can cause overheating and a fire.
- If the plug is wet or dirty, dry or wipe it clean before use.

-
- Do not use the electrical outlet if it's not compatible with the power cord plug.
 - You should only use standard multi-outlet power strips.
- 2) You should only use the adapter provided in this package.
 - It is not safe to use other adapters.
 - 3) Do not unplug it by pulling on the power cord
 - This may damage the power cord and cause a fire or printer malfunction.
 - 4) Do not plug or unplug the power cord with wet hands.
 - This may cause electric shock.
 - 5) Do not bend the power cord excessively or place heavy objects on it
 - Damaged power cords may cause a fire.

⚠ Note: Violating following instructions can cause slight wound or damage the appliance .

- 1) If you find smoke, smell or noise coming out of the printer for unknown reason, please unplug the power cord and take proper emergency measures.
 - Turn off the printer and unplug power cord.
 - After the smoke clears, call the dealer for repairs.
 - 2) Place the printer on a stable and flat surface.
 - If the printer drops to the ground, it may break and cause personal injury.
 - 3) You should only use approved accessories, and do not attempt to disassemble, repair or modify the printer by yourself.
 - Please call the dealer if you need any of the above-mentioned services.
 - 4) Do not let water or other objects get inside the printer.
 - In case it happens, turn off the printer and unplug the power cord. Then call the dealer for service.
 - 5) Do not use the printer when there is a malfunction, as this may cause fire or electric shock.
 - Please turn off the printer and unplug the power cord. Then call the dealer for service.
-

6) Other matters to note.

Leave enough space around the printer for operation and maintenance purpose

Keep the printer away from water, direct sunlight, strong light and heat sources.

Do not use or store the printer in places with high temperature, high humidity or heavy pollution.

Avoid placing the printer in places subject to vibrations and shocks.

Connect the printer's power adapter to a properly grounded electrical outlet, and avoid using the same outlet with large appliances or devices that can cause voltage fluctuations.

Please disconnect the power supply if you are not going to use the printer for a long period of time.

To ensure print quality and extend the life of the printer, it is suggested to use recommended or equivalent quality printer paper.

Shut off the power before plugging or disconnecting of interfaces, otherwise it may damage the printer control circuits.

Please keep this manual in a proper place for future references.

3. Other matters to note

Although we have been very careful on the compiling of this manual, however, errors and/or omissions are still inevitable. The company will not assume any responsibility for any losses on anyone due to the use of information in this manual. For users and third parties, the company and its subsidiaries will not be liable for any product damage, failure or misuse caused by not following or ignoring the operation, maintenance information and/or instructions provided by the company; and for losses, costs or expenses caused by unauthorized changes, repairs or modifications to the product. The company shall not bear any responsibility with regard to damages and/or problems caused by the use of counterfeit accessories, parts or unauthorized products.

Note: Due to continuous product improvement, specifications, accessories and/or procedures described herein are subject to change without notice.

4.WEEE (Waste Electrical and Electronic Equipment)



The symbol placed on the product indicates that the item should not be mixed with general household waste. If such waste is not properly managed, it may harm both environment and human health. To prevent possible harm to the environment or human health from uncontrolled waste disposal, please separate these items from other types of waste and recycle them responsibly to promote the sustainable reuse of material resources. Household users should contact either the retailer where they purchased this product, or their local government office, for details of where and how they can take these items for environmentally safe recycling. Business users should contact their supplier and check the terms and conditions of the purchase contract. This product and its accessories should not be mixed with other commercial wastes for disposal.

1 PRODUCT INTRODUCTION

1.1 Unpacking checklist

- 1) Unpack the printer and save the packing materials in case you need to repack the printer for shipping or storage.
- 2) Please contact the dealer for any defect and/or missing of accessory.

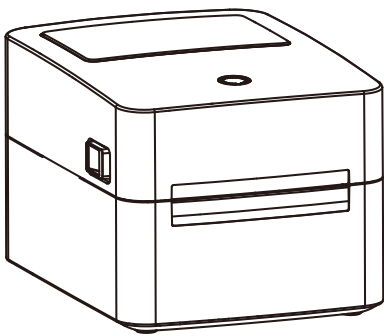

Printer

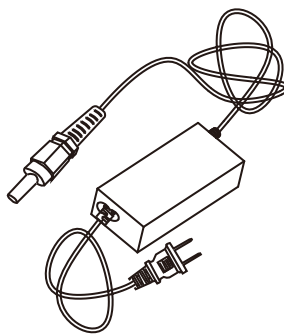

Power cord

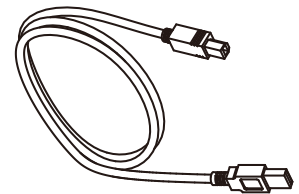

USB cable

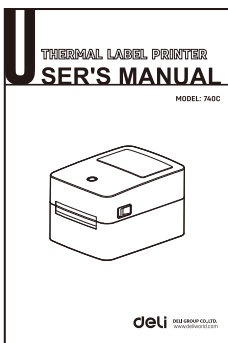

User manual

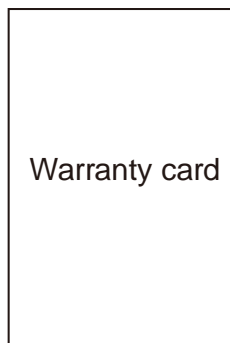

Warranty card

1.2. Physical appearance and components

paper feed button(status indicator)

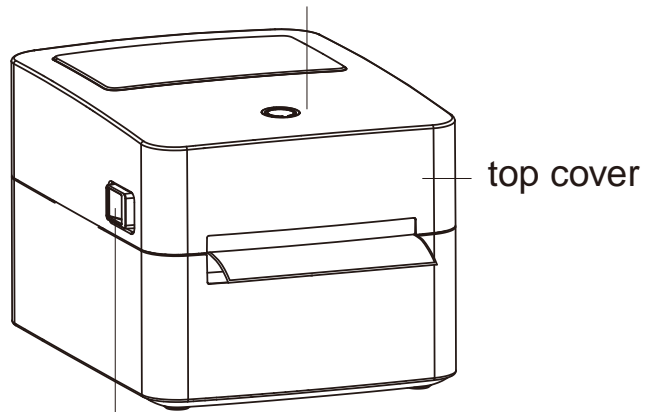

top cover release button

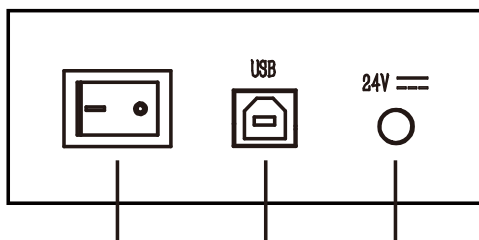

power switch USB port power connector

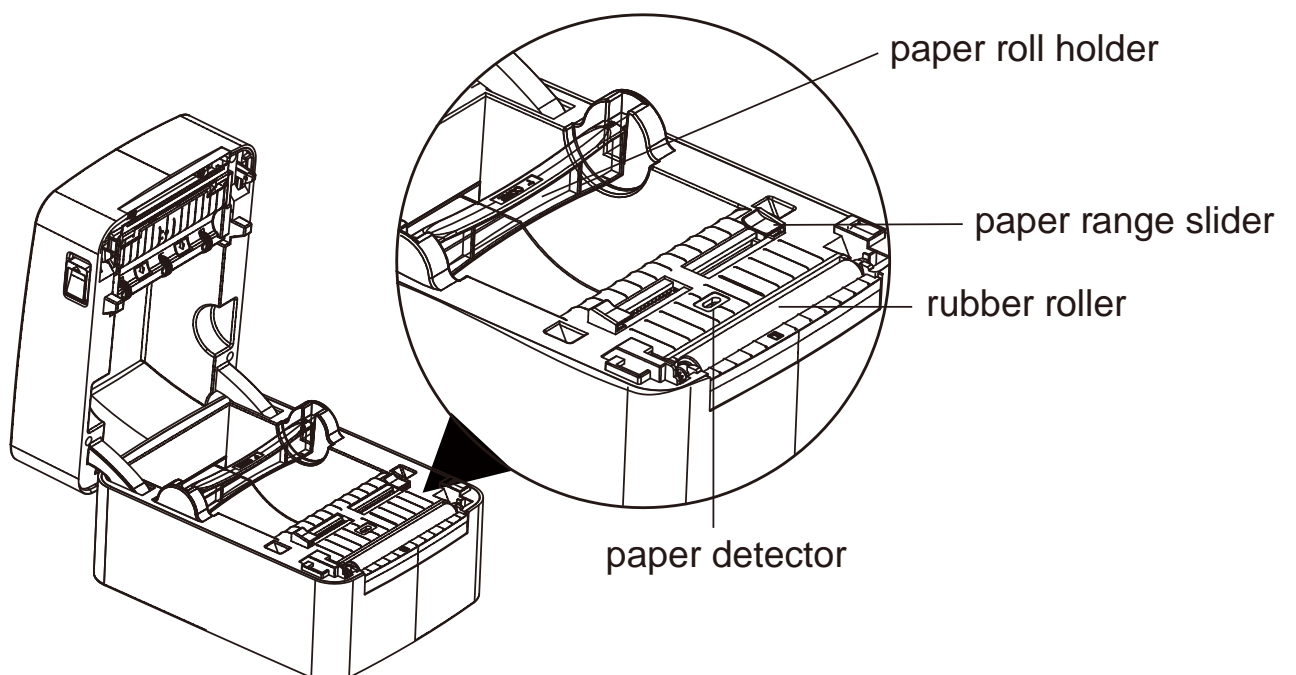
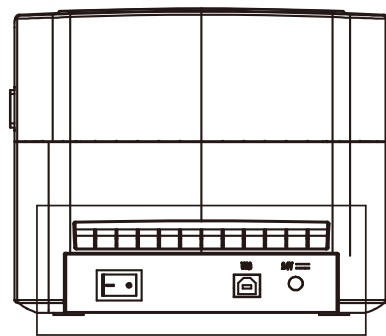

1.3 Product dimensions

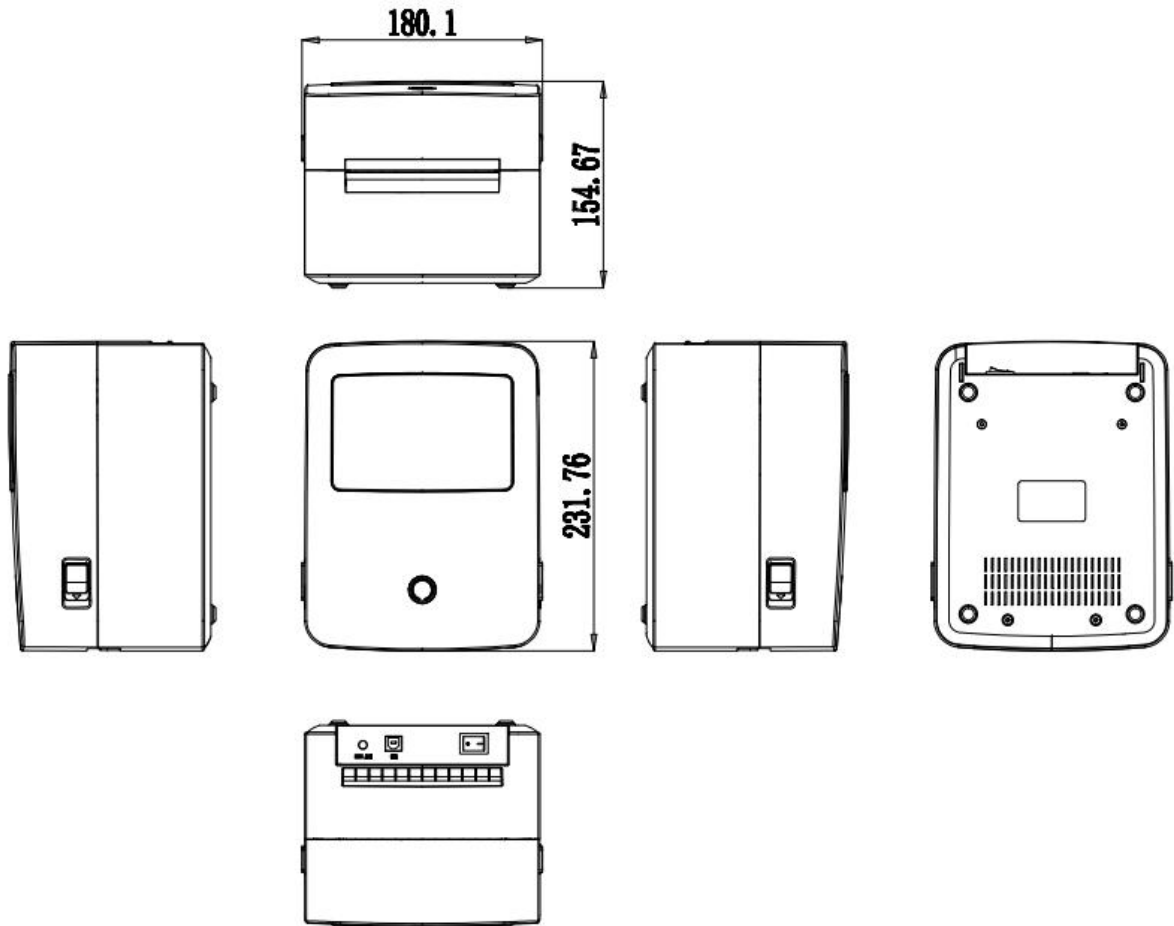

Unit: mm

2 PRODUCT SPECIFICATIONS

Item		Parameter
Printing	Print method	Direct thermal
	Print resolution	203 dpi 8 dots/ mm
	Printing speed	70mm/s
	Print width	48mm
	Print length	15-300mm
Processor		32-bit RSIC
Memory	RAM	2MB
	Flash memory (optional)	16MB
Detection	Sensor	Stationary out of paper detection, cover-open detection, seam mark detection, black mark detection.
Paper supplies	Type	Fold or roll paper, black mark continuous roll labels
	Width	0.79"(20 mm)– 4.65"(118 mm)
	Thickness	0.003" (76.2 μm)–0.007"(177.8 μm)
	Paper roll diameter	4.72 " (120 mm)
	Core inner diameter	1.0" (25.4 mm) , 1.5" (38 mm)
Programming language		TSPL
Software function	Driver	Windows XP/Win7/Win8/Win10/Vista
	Label design	Deli BarTender Ultralite 2016
Built-in fonts		GB18030 16×16 24×24 32×32dots ASCII 8×16 12×24 16×32dots
Barcodes	1D	Code 39, Code 93, Code 128UCC, Code 128 subset A, B, C, Codabar, Interleave2of5, EAN-8, EAN-13, EAN-128
	2D	QR Code PDF417 aDataMatrix
Interface		USB
Human-machine interface		Paper feed button with three-color light
Power Adapter		Power on/o Input: DC 100-240V, 50/60 Hz, output: DC 24V/2A
Environment parameters	Operating	5 to 50 ℃, 25% to 85%RH(no condensation)
	Storage	–40 to 60 ℃, 10% to 90%RH(no condensation)
Physical parameters	Dimensions (LxHxW)	231.7X80.1X 154.7mm
	Weight	2.0 kg (without consumables)
Options and accessories		External label roll holder or folding paper container
Certificate		CE

3 INSTALLATION AND OPERATION

3.1 Installation media

3.1.1 Installing the paper roll

1. Stand in front of the printer and follow the arrow to open the receipt cover by pushing it up.

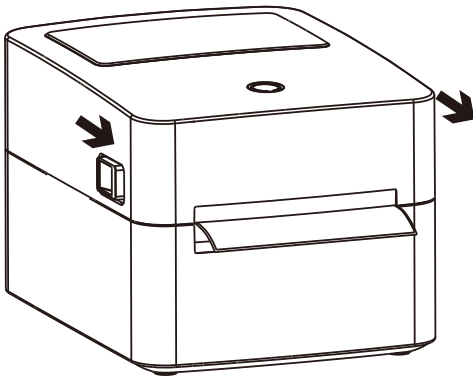

2. Hold the paper scroll and take out the paper scroll upwards.

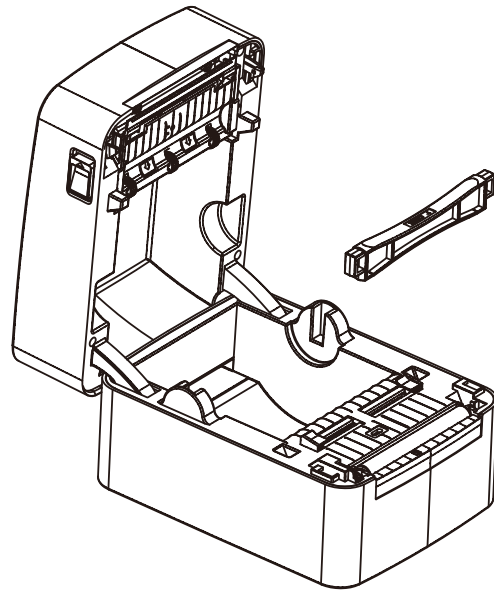

3. In accordance with the inner diameter of the paper roll, load the paper roll into the paper scroll.

- ① When using a 1-inch paper roll, please load the paper scroll with the 1-core side facing up

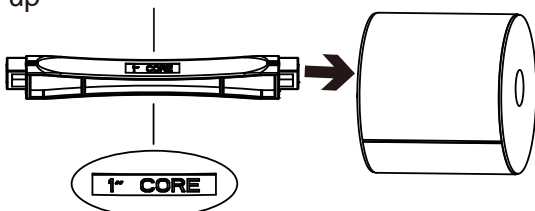

- ② When using a 1.5-inch paper roll, please mark the paper scroll with a 1.5 core face up, load paper roll

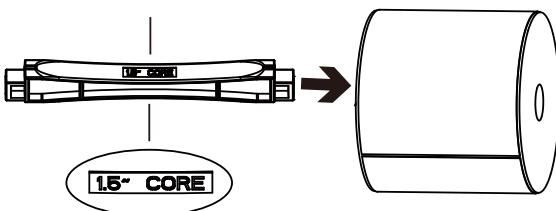

4. Load the paper roll set into the printer from top to bottom.

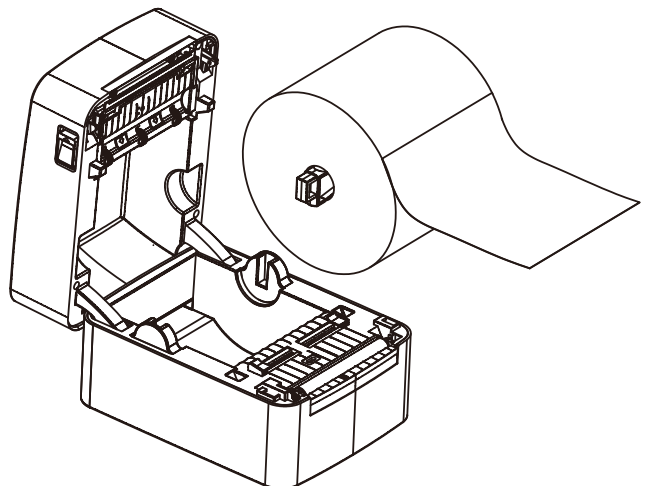

5. Pull out part of the paper roll through the paper guide, and close the paper guide according to the paper width to regulate both sides of the paper.

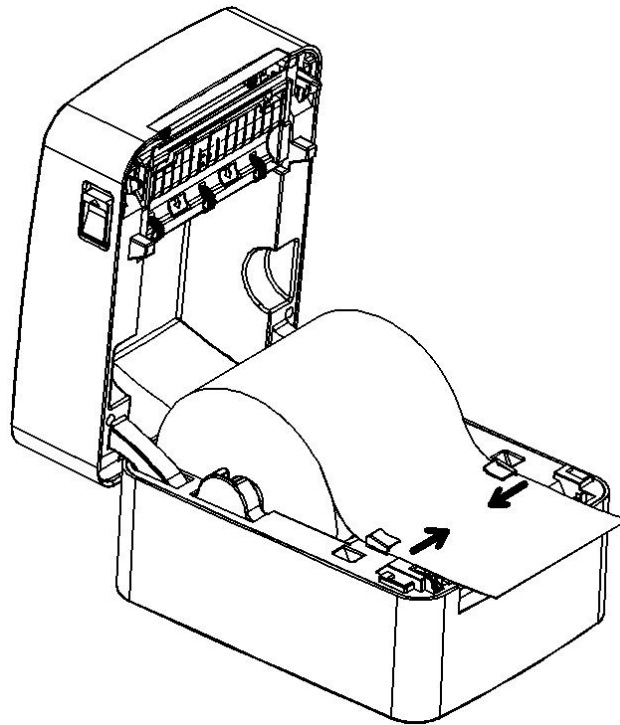

6. Press down until you hear a click. Tear off any excess paper in the direction of the cutting blades.

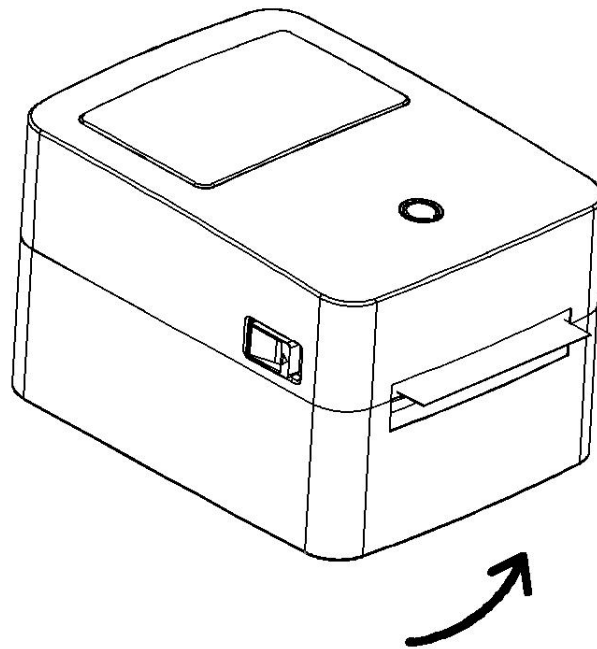

3.1.2 Installing folding paper

1. Place the folded label paper at the back of the printer. With the printing side facing up, insert into the printer from the external paper roll inlet.

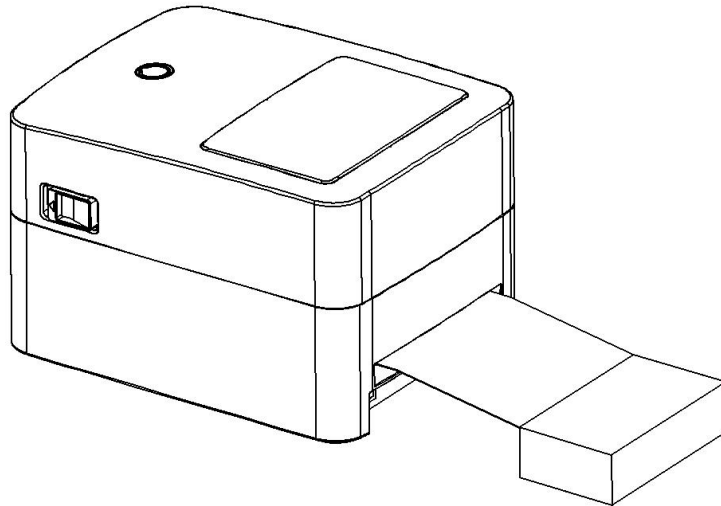

2. Open the printer top cover, pull out the paper roll to the front of the printer, and adjust the paper guide according to the paper size.

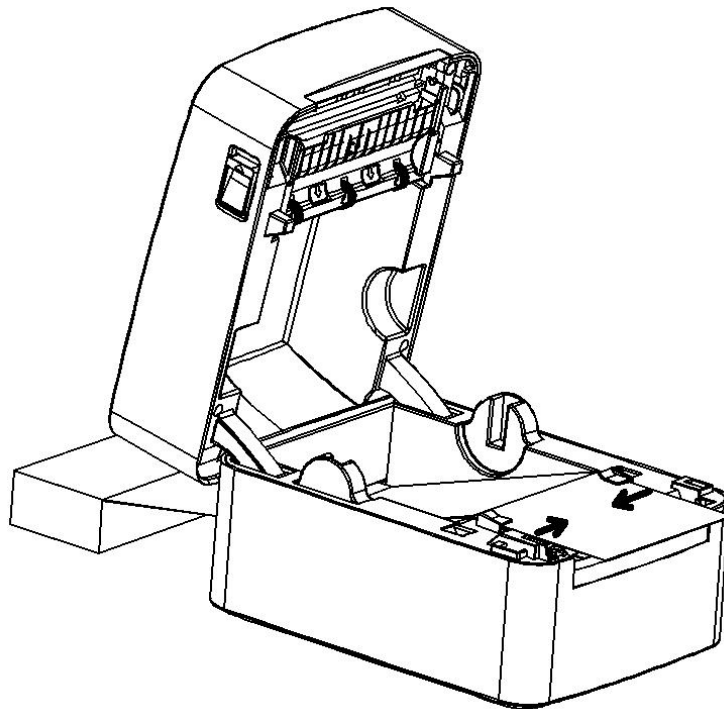

3. Press down the top cover until it locks with a click.

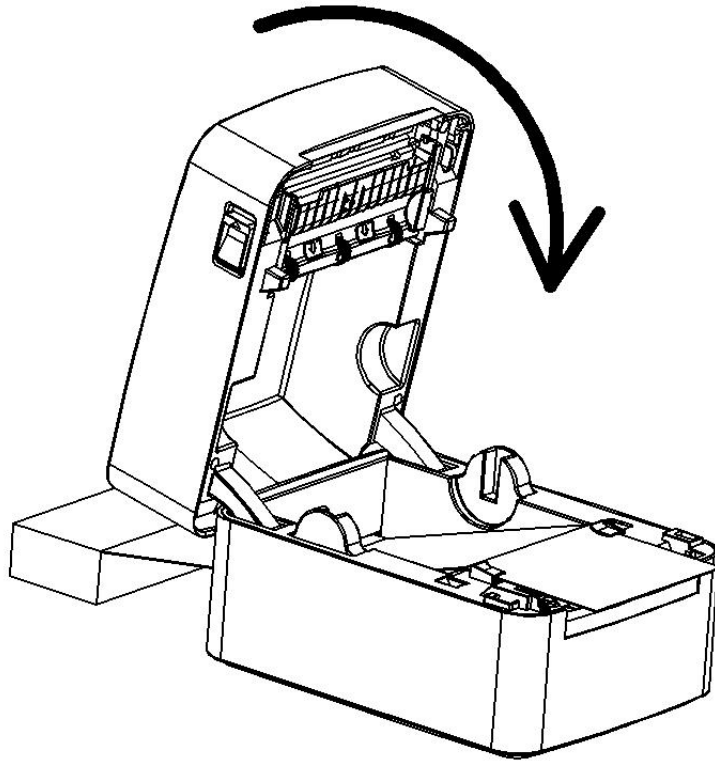

3.1.3 Installing the external paper roll bracket

When folding paper is used, or the paper roll is too large to be put into the paper bin, you can feed the paper from the paper inlet of the external paper roll as shown in the figure below, and then pass the paper underneath the paper guide, adjust the guide based on the paper width to regulate the paper.

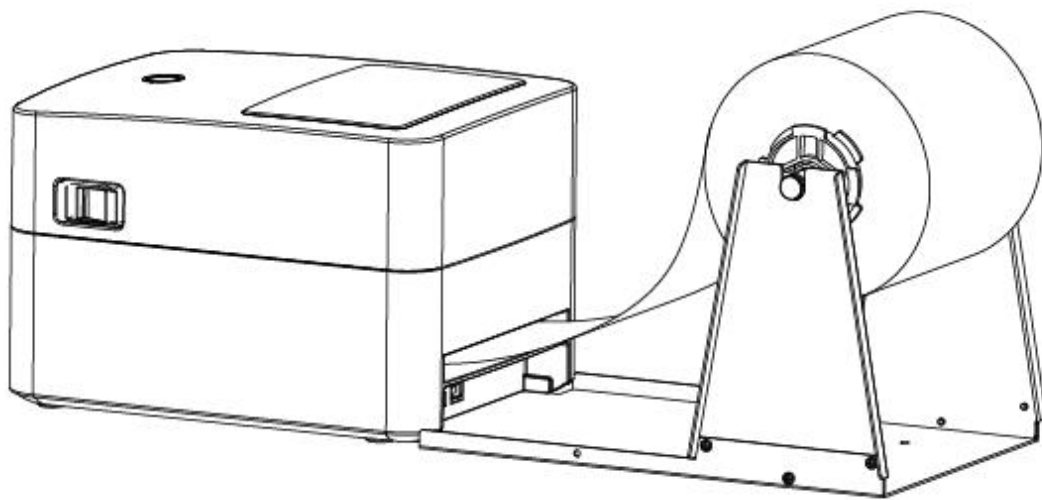

Note: The paper roll bracket can be fixed on both sides with locking pins.

3.2 Power connection

1. Make sure the printer's power switch is o (O).
2. Connect the power adapter to the printer.
3. Connect the power cable to the power adapter.
4. Plug the power cord into the other end of the power supply.

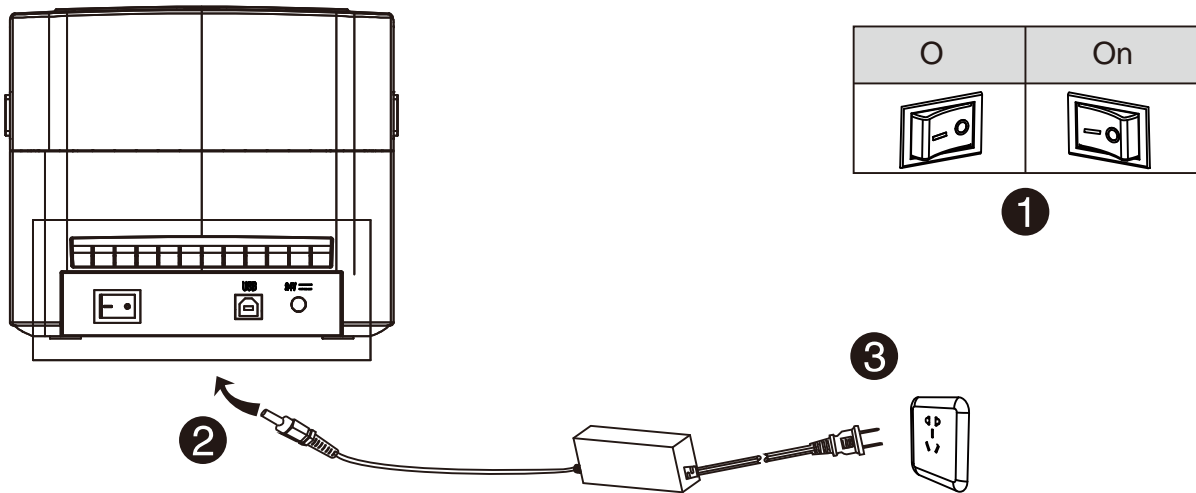

Note

Please use our company's original power adapter to avoid damage to the product and the possible cause of injury.

Please disconnect the power supply if you are not going to use the printer for a long period of time

Power is interrupted, or the data cable becomes disconnected during printing: When all data has been transmitted to the printer and the power or data cable becomes disconnected, the unprinted content will not be printed or reprinted. When the data is partially transmitted to the printer, any unprinted content will be reprinted after the power and data cables are reconnected.

3.3 Interface connection

Connect the interface cable as shown in the figure below.

This printer supports the following communication interface standards:

--USB B-Type cable

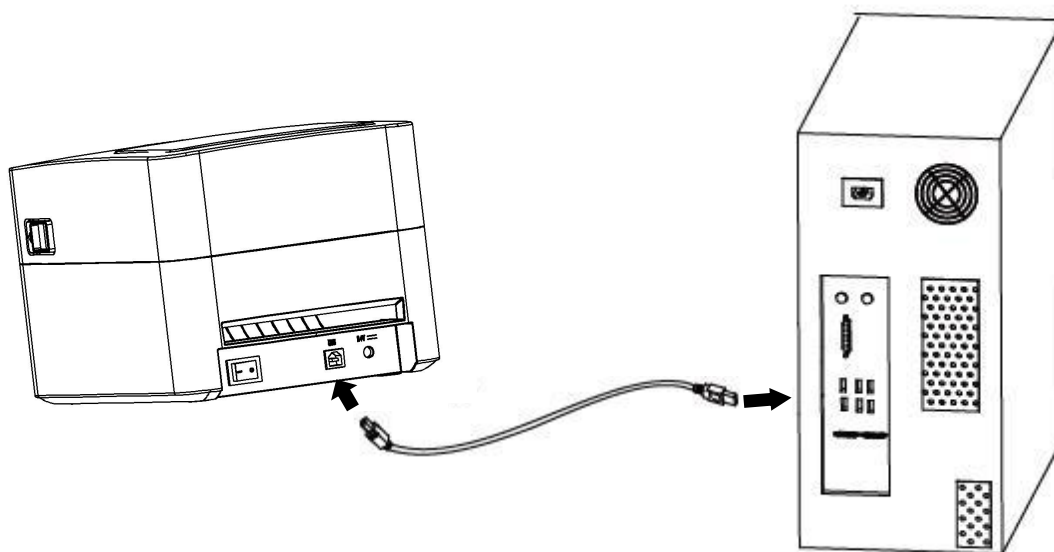

1) Turn off the printer (O).

2) Please plug the communication cable to into the corresponding communication connectors of printer.

—USB port insert --USB B-Type cable

3.4 Label detection

DL-740C(NEW) uses label paper (Figure 1) or black label paper (Figure 2), which requires label detection before normal paper feeding and printing.

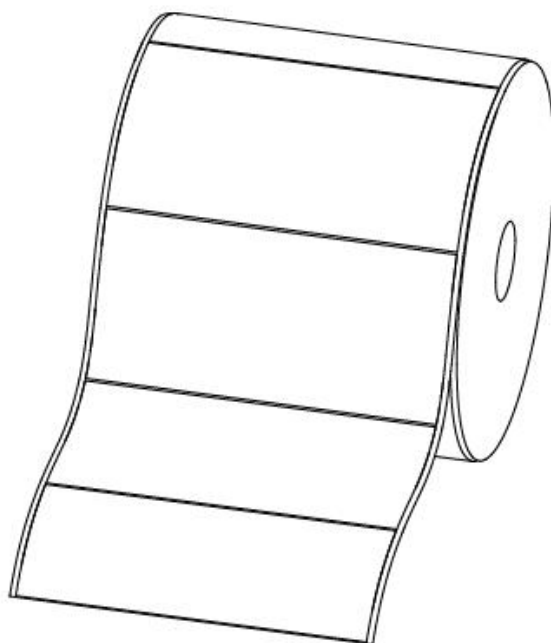

label paper (Figure 1)

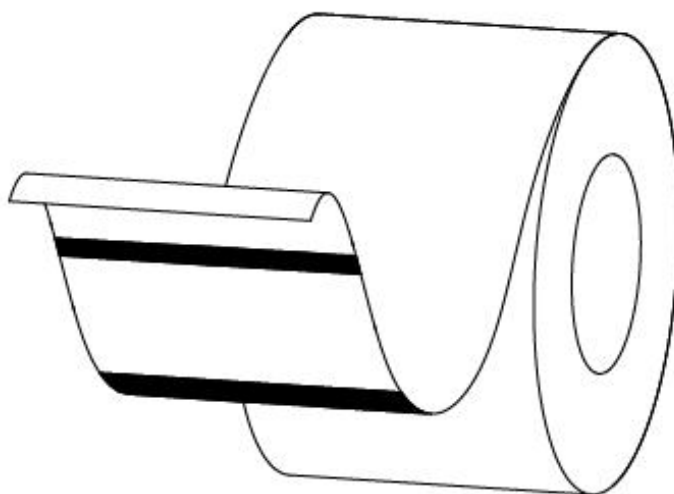

black label paper (Figure 2)

3.5 Operation panel

Power-on:

When connected to power supply, move the power switch on the back side of the printer into the On position, the printer turns on and the indicator light is on.

Power-off :

Move the power switch on the back side of the printer into the Off position, the printer turns off and the indicator light is off.

Paper feed:

1. Press the paper feed button and the printer will feed the paper to the specified outlet according to the type of paper used. For continuous paper, press and hold the paper feed button and the printer will feed a fixed length of paper; if you are using label paper, press the paper feed button once to feed out a whole page of label.
2. Press the paper feed button to pause the current printing task and the indicator light turns white (blue, green, red), press this button again to resume the unfinished printing task;

Description for indicator status

Color	Status	Printer status
Blue	On	Printer is ready for operation
Purple	On	Printer head is overheated
Red	On	The top cover is not closed in place
Red	Blinks slowly	Out of paper or paper jam
Red	Blinks fast	Abnormal label printing training
Orange	On	Printer is not ready for operation
Green	On	Printing in progress
Green	Blinks slowly	Printer paused
White	On	RAM test failed (printer can't start)
Orange	Blinks fast	Abnormal voltage, DC input less than 21V, or greater than 26V (printer can't start)

3.6 Basic function

3.6.1 Power ON/OFF

Press "O" to turn off the power;

Press "I" to turn on the power.

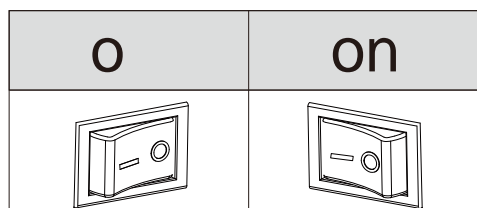

3.6.2 Printing test

When the printer is initially installed, or if there is any problem with the printer, you can execute the self-check program to confirm the following status. Hardware version, printer parameter setting status. If you confirm no problems with the printer after the self-check, such as printing quality and related setting information of external devices, please check other devices or software. This function runs independently with other devices or software.

This is the self-test process:

- 1) Ensure the power is connected, and the paper roll is properly installed.
- 2) Turn on the printer.
- 3) When the indicator light (blue) blinks or when you hear beep, release the button and the printer will initiate intelligent detection. Wait until the red light is off, release the paper feed button to print the printer self-check page.

3.6.3 Label printing training

1. Under the following situations, the users may learn about label positioning so that printer can better position the labels .

Set up your printer for the first time;

Use the printer for the first time after the sensor is cleaned;

Reuse the printer after a period of not using;

Change a new type of paper roll;

The printer cannot effectively recognize the symbol during the printing process;

The surrounding environment of the printer has been changed significantly;

2. How to determine your label position

Turn on the printer, press and hold the paper feed button; When the indicator light (blue) blinks for the second time or when you hear two consecutive beeps, release the button and the printer will initiate intelligent detection; When the learning is finished, press the paper feed button once and one label will be feed out normally, indicating that you have completed the detection process. The method can also be applied for black continuous paper label.

Note: When pressing the paper feed button, do not cover the indicator light so that you can observe the status of the indicator.

3.6.4 First Page Rollback

When the printer is turned on, and the length of the paper out of the printer is less than 80 mm, the paper can be rollbacked to tear-off position to avoid waste.

Note: Please use the "First Page Rollback" function indoors without direct sunlight;

When the printer is exposed to strong light, it is recommended to disable the "First Page Rollback" function.

4 INTERFACE SIGNAL

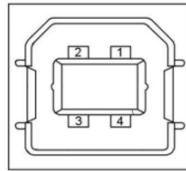

Pin number	Signal name
1	VBUS
2	D-
3	D+
4	GND

5 CLEANING THE PRINTER

Printing quality might be degraded by dust, foreign substance, adhesive substance, or other pollution materials stuck in the printer head or inside the printer. When dirty, clean the print head as follows

Caution

- 1) Make sure to turn the printer power off prior to cleaning.
- 2) Turn the printer off and wait for 2 -3 minutes before cleaning the printhead because it gets very hot during the printing process.
- 3) When cleaning the print head, take care not to touch the heated portion of the print head to avoid any damage caused by static electricity or other factors.
- 4) Take care not to allow the print head to become scratched and/or damaged in any way.

5.1 Cleaning the print head

- 1) Open the top cover of the printer, and then use the cleaning pen or a cotton swab dipped in diluted alcohol (or isopropanol) to clean the print head in the direction from the center of the head to the edges.
- 2) After cleaning the head, do not use the printer until the alcohol used for cleaning evaporates completely (1~2 min) and the printer head has completely dried.

5.2 Cleaning the sensor, roller and paper path

- 1) Open the top cover of the printer and take out the paper roller.
- 2) Remove any dust or foreign materials using a dry cotton cloth or cotton swabs.
- 3) Use an alcohol-soaked cotton cloth or cotton swabs to wipe off any adhesive substance or pollution materials
- 4) After cleaning the parts, do not use the printer until the alcohol used for cleaning evaporates completely (1~2 min) and the printer has completely dried.

Please clean the parts in case the print quality deteriorates or paper detection performance decreases